

Conveyor chains (FV series)

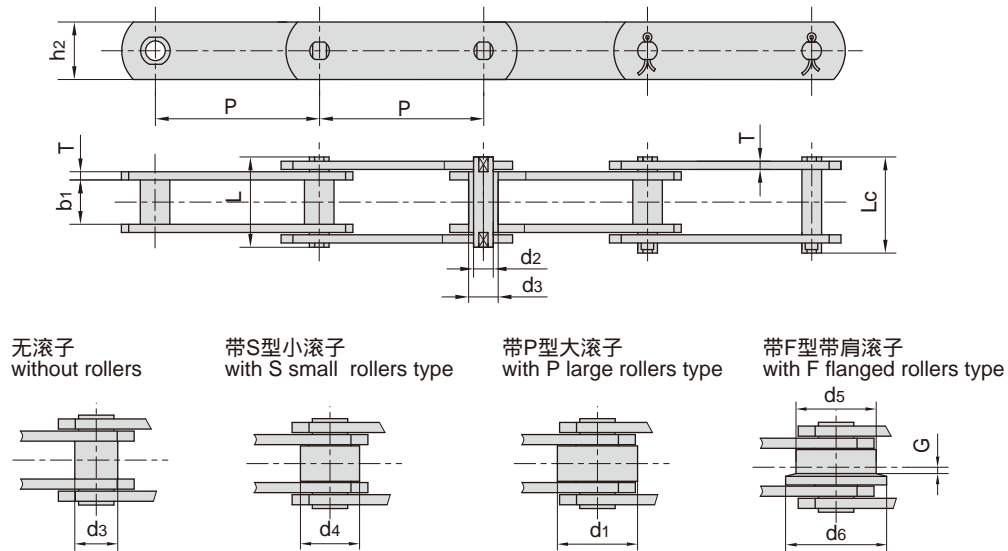

DIN 链号 DIN Chain No.	节距 Pitch							滚子尺寸 Roller dimension					套筒直径 Bush diameter
	P							d1 max	d4 max	d5 max	d6 max	G	d3 max
	mm	mm	mm	mm	mm	mm	mm	mm	mm	mm	mm	mm	
FV40	50.0	63.0	80.0	100.0	125.0	-	-	32.0	20.0	40.0	50.0	4.0	15.0
FV63	50.0	63.0	80.0	100.0	125.0	160.0	-	40.0	26.0	50.0	63.0	5.0	18.0
FV90	63.0	80.0	100.0	125.0	160.0	200.0	250.0	48.0	30.0	63.0	78.0	6.5	20.0
FV112	80.0	100.0	125.0	160.0	200.0	250.0	-	55.0	32.0	72.0	90.0	7.5	22.0
FV140	63.0	100.0	125.0	160.0	200.0	250.0	-	60.0	36.0	80.0	100.0	9.0	26.0
FV180	100.0	125.0	160.0	200.0	250.0	315.0	-	70.0	42.0	100.0	125.0	13.0	30.0
FV250	125.0	160.0	200.0	250.0	315.0	400.0	-	80.0	50.0	125.0	155.0	15.0	36.0
FV315	160.0	200.0	250.0	315.0	400.0	-	-	90.0	60.0	140.0	175.0	18.0	42.0

DIN 链号 DIN Chain No.	内节内宽 Width between inner plates	销轴直径 pin diameter	销轴长度 Pin length		链板高度 Plate depth	链板厚度 Plate thickness	抗拉强度 Tensile strength	
	b1 min	d2 max	L min	Lc max	h2 max	T max	Q min	*Q min
	mm	mm	mm	mm	mm	mm	kN/lbf	kN/lbf
FV40	18.0	10.0	36.0	39.0	25.0	3.0	40.0/9091	47.0/10681
FV63	22.0	12.0	45.0	48.5	30.0	4.0	63.0/14317	75.0/17045
FV90	25.0	14.0	53.0	56.5	35.0	5.0	90.0/20453	115.0/26136
FV112	30.0	16.0	62.0	66.0	40.0	6.0	112.0/25452	170.0/38636
FV140	35.0	18.0	67.0	71.5	45.0	6.0	140.0/31815	180.0/40908
FV180	45.0	20.0	86.0	92.0	50.0	8.0	180.0/40908	250.0/56817
FV250	55.0	26.0	97.0	103.5	60.0	8.0	250.0/56817	300.0/68181
FV315	65.0	30.0	113.0	126.5	70.0	10.0	315.0/71591	480.0/109089

*Q 表示热处理后的抗拉强度

*Q denotes the tensile strength after hardened

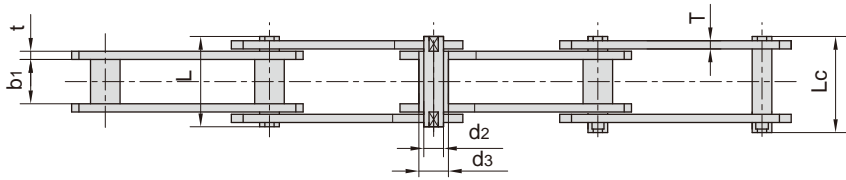

无滚子
without rollers

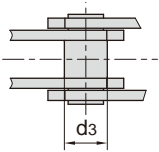

带S型小滚子
with S small rollers type

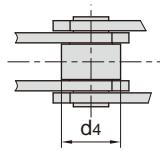

带P型大滚子
with P large rollers type

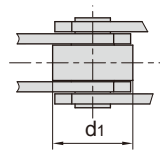

带F型带肩滚子
with F flanged rollers type

