

Conveyor chains with special rollers

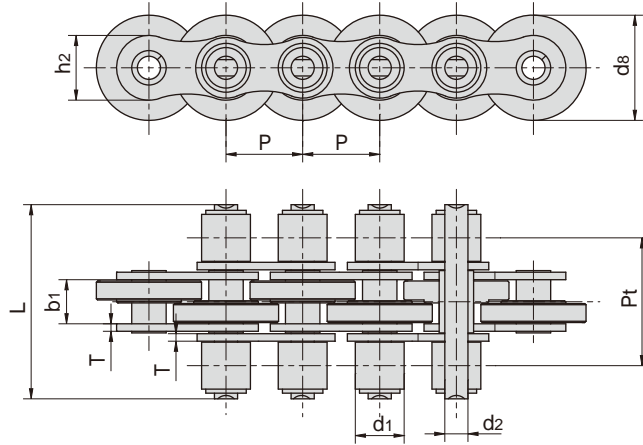

东华链号 Donghua Chain No.	节距 Pitch	滚子直径 Roller diameter		内节内宽 Width between inner plates	销轴直径 Pin diameter	销轴长度 Pin length	链板尺寸 Plate dimension		排距 Transverse pitch	抗拉强度 Tensile strength	平均抗拉强度 Average tensile strength
	P	d1 max	d8 max	b1 min	d2 max	L max	h2 max	T max	Pt	Q min	Q0
	mm	mm	mm	mm	mm	mm	mm	mm	mm	kN/lbf	kN
12BS3-40-C27/P27	19.05	12.07	27.0	11.68	5.72	40.0	16.0	1.85	27.0	29.0/6519	34.8
12BS3F1-48-C26	19.05	12.07	26.0	11.40	5.72	48.0	16.0	1.85	31.7	29.0/6519	34.8

注: P表示滚子材料塑料, C表示滚子材料为钢
Note: P means roller made in plastic, C means roller made in steel

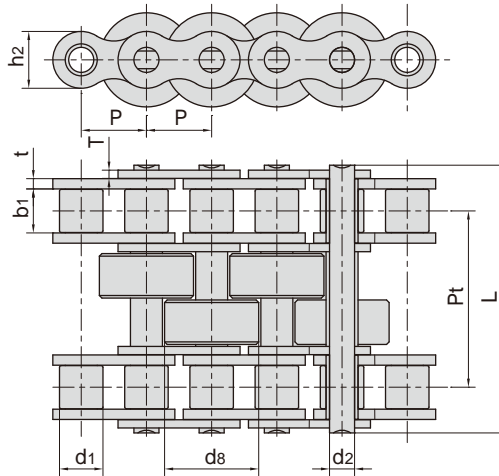

东华链号 Donghua Chain No.	节距 Pitch	滚子直径 Roller diameter		内节内宽 Width between inner plates	销轴直径 Pin diameter	销轴长度 Pin length	链板尺寸 Plate dimension		排距 Transverse pitch	抗拉强度 Tensile strength	平均抗拉强度 Average tensile strength
	P	d1 max	d8 max	b1 min	d2 max	L max	h2 max	t/T max	Pt	Q min	Q0
	mm	mm	mm	mm	mm	mm	mm	mm	mm	kN/lbf	kN
24BF28-PA6	38.100	25.40	55.00	25.40	14.63	156.80	33.20	6.0/4.8	103.0	280.0/62944	308.0
24BSF2-2	38.100	25.40	55.00	25.40	14.63	156.80	33.20	6.0/4.8	102.8	280.0/62944	308.0

注: P表示滚子材料为塑料, C表示滚子材料为钢
Note: P means roller made in plastic, C means roller made in steel

Conveyor chains with special rollers

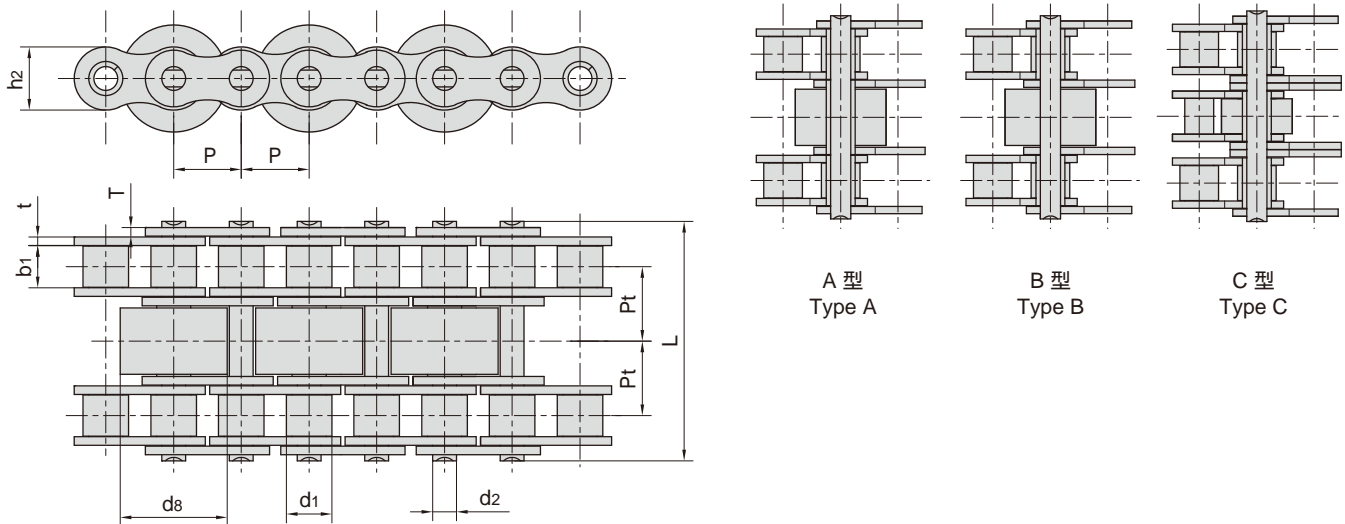

东华链号 Donghua Chain No.	节距	滚子直径		内节内宽	销轴直径	销轴长度	链板尺寸		排距	抗拉强度	平均抗拉强度	型号
	Pitch	Roller diameter		Width between inner plates	Pin diameter	Pin length	Plate dimension		Transverse pitch	Tensile strength	Average tensile strength	Type
	P	d1 max	d8 max	b1 min	d2 max	L max	h2 max	t/T max	Pt	Q min	Q0	
	mm	mm	mm	mm	mm	mm	mm	mm	mm	kN/lbf	kN	
06BF52-C14.5/P14.5	9.525	6.35	14.50	5.72	3.28	33.5	8.2	1.30	10.24	14.0/3147	16.1	B
06BS-3-C15/P15	9.525	6.35	15.00	5.72	3.28	33.5	8.2	1.30	10.24	16.9/3841	18.7	B
A06BF3S-3-C15/P15	9.525	6.35	15.00	5.72	3.28	33.5	8.4	1.30	10.24	16.9/3841	18.7	B
08BS-3-45-C16	12.700	8.51	16.00	7.75	4.45	45.1	11.8	1.60	13.92	32.0/7273	38.7	A
08BS-3-45-C17	12.700	8.51	17.00	7.75	4.45	45.1	11.8	1.60	13.92	32.0/7273	38.7	A
08BS-3-45-C20	12.700	8.51	20.00	7.75	4.45	45.1	11.8	1.60	13.92	32.0/7273	38.7	A
08BSF1-3-45-C17	12.700	8.51	17.00	7.75	4.45	45.5	11.8	1.60	14.23	32.0/7273	38.7	A
08BSF6-3-45-C20	12.700	8.51	20.00	7.75	4.45	45.1	11.8	1.60	13.92	32.0/7273	38.7	B
12AF107-3-71-C28	19.050	11.91	28.58	12.57	5.94	71.5	18.0	2.42	22.78	62.6/14072	72.0	C
12AF122-2	19.050	11.91	28.00	12.57	5.94	65.3	18.0	2.42	19.60	62.3/14005	71.6	B
12AF127-3-P29	19.050	11.91	29.00	12.70	5.94	71.5	18.0	2.42	22.80	62.6/14072	72.0	B
12AF90-3-71-C28	19.050	11.91	28.58	12.57	5.94	71.5	18.0	2.42	22.78	62.6/14072	72.0	B
12ASF1-3-62-C26	19.050	11.91	25.90	12.57	5.94	62.0	18.0	2.42	17.87	62.6/14072	72.0	A
12ASF2-3-81-P28.4	19.050	11.91	28.40	12.57	5.94	81.0	18.0	2.42	27.42	62.6/14072	72.0	B
12BF45-3-C28/P28	19.050	12.07	28.00	11.68	5.72	61.5	16.0	1.85	19.46	57.8/12993	66.5	B
12BS-3-62-C24	19.050	12.07	24.00	11.68	5.72	61.5	16.0	1.85	19.46	57.8/12993	66.5	A
12BS-3-62-C26	19.050	12.07	26.00	11.68	5.72	61.5	16.0	1.85	19.46	57.8/12993	66.5	A
12BS-3-62-C28/P28	19.050	12.07	28.00	11.68	5.72	61.5	16.0	1.85	19.46	57.8/12993	66.5	A
12BS-3-62-C31	19.050	12.07	31.00	11.68	5.72	61.5	16.0	1.85	19.46	57.8/12993	66.5	B
12BSF10-3-62-C26	19.050	12.07	26.00	11.68	5.72	61.5	16.0	1.85	19.46	86.7/19705	101.8	C
12BSF10-3-62-C28	19.050	12.07	28.00	11.68	5.72	61.5	16.0	1.85	19.46	86.7/19705	101.8	C
16SB-3-100-C38	25.400	15.88	38.50	17.02	8.28	99.8	21.0	4.15/3.10	31.88	160.0/35968	184.0	C
C212BSF1-3-62-C32	38.100	12.07	32.00	11.68	5.72	61.5	16.0	1.85	19.46	57.8/12993	66.5	B
C2082HF80-2-PA6	50.800	28.58	45.00	15.75	7.92	108.0	24.0	4.00	35.65	94.0/21131	108.1	C

注: P 表示滚子材料为塑料, C 表示滚子材料为钢。
Note: P means roller made in plastic, C means roller made in steel.